

APPLICATION OF PHOTOVOLTAIC POWER FOR COOLING SYSTEMS

***Syafaruddin, Sri Mawar Said, Faharuddin,
Moeh. R. Adymulya**
Universitas Hasanuddin
Makassar, Sulawesi Selatan, Indonesia

Satriani Latief
Universitas Bosowa
Makassar, Sulawesi Selatan, Indonesia

Keywords: Solar energy, photovoltaic module, cooling systems, refrigerant media

** Corresponding author: Department of Electrical Engineering, Universitas Hasanuddin, Jl. Poros Sungguminasa-Malino Km.8, Kabupaten Gowa, Sulawesi Selatan, 92171, Indonesia, Phone/Fax: +62-411-586015
E-mail address: syafaruddin@unhas.ac.id*

ABSTRACT

The solar energy for cooling system is one of the important applications in equator region. It is due to daily hot weather condition that results in the extremely high need of electricity consumption for air conditioning system. Nevertheless, the good news is the abundance of sun light energy that can be used to power the photovoltaic (PV) systems by means for the cooling system applications. In this case, the paper presents the cooling systems powered by the photovoltaic systems by extracting the heat through the extraction box designed at the backside of PV module. The water is used as the medium heat transfer, while the refrigerant is used as the working fluid in the cooling engine. In this study, the effectiveness of R22 and R134a refrigerants is compared in terms of producing lower cold temperature under different refrigerant pressures of 1 bar and 2 bars. Only small portion of electricity energy output of PV module is utilized for our designed cooling systems that make the PV module performance in terms of efficiency will be maintained high.

INTRODUCTION

Utilization of solar energy into useful energy can be found in different types of energy conversion. The most common application is to utilize the heat energy directly for heating system, such as room temperature adjustment during winter time or just simple for food preservation. Nowadays, it is also well-known about the transfer of solar energy into electricity energy either by direct or indirect conversion. The direct conversion of sunlight into electricity is known as photovoltaic (PV) systems, while the indirect conversion is known as the solar thermal power systems. The uncommon application is actually to utilize the solar energy for cooling system. Such type of cooling system application is one of the most important applications in equator

region due to hot daily temperature condition and high humidity. In addition, it is noticeable that significant portion of energy consumption goes to the air cooling system. Nevertheless, the abundance of sunlight energy in equator region can be used for the additional energy sources in different applications.

Conventional cooling system works basically following the principle of heat transfer. Initially, the compressor section functions as the driving force to drain the Freon refrigerant in the tube. The compressor motor rotates and provides pressure to all cooling materials. The refrigerant when given the pressure will be the gas pressure with high temperature. This is the reason why the electricity consumption for cooling system is quite high because the use of compressor to circulate and to raise the temperature of refrigerant. In this research, the use of electrical power can be saved by utilizing of solar energy for cooling systems. The heat energy from sunlight can be used to replace the function of compressor to raise the temperature of the refrigerant. In addition, the proposed cooling system may maintain the electricity power consumption from PV module after utilizing the low-power motor for water and refrigerant circulations.

The heat collected from the backside of PV module is utilized to raise the temperature and pressure of refrigerant of cooling system. The mechanism is to heat the water until reaching certain temperature which is good enough to raise the temperature of liquid refrigerant and make it evaporate. The evaporated refrigerant will be sucked by the vacuum motor so that it flows to the cooling tank. In the cooling tank, the evaporated refrigerant will be transformed back into liquid through condensation process so that the temperature in the

cooling tank is going down and be cool. Such condition is utilized by transferring the cold temperature of the cooling tank into the room through the water medium which is diverted through a pipe connected between the cooling tank and the room. The cold water temperature is then exhaled to make the room air temperature decreases and becomes colder.

Utilization of thermal energy by means the photovoltaic-thermal systems has been investigated in order to improve the efficiency performance of photovoltaic systems. The electrical efficiency is denoted very low; however, the overall efficiency can be improved by simultaneously obtaining the thermal energy for heating systems [1]. In this case, the extraction of heat energy by fluid media provides some kind of radiator or cooling systems and this approach enhances indirectly the electrical efficiency of photovoltaic systems since the heat degrading the output voltage and power as well, especially for polycrystalline solar cell materials [2]. The heat removal by air or water prevents the deterioration of the PV cell efficiency due to the overheating of cells [3]. The benefits of thermal energy on rooftop household photovoltaic systems has also been investigated for drying systems and the economic impact might be obtained from such household utilization [4]. More detail about the performance of water as regime fluid for photovoltaic thermal system is evaluated regarding the other supporting components in order to maximize the exergy efficiency thermal [5]. The important point for thermal utilization of photovoltaic system requires constant research support and challenges in order to maximize the benefits performance of building integrated photovoltaic thermal systems [6].

The cooling system is important either to improve the photovoltaic system performance or to be target dehumidify system as further utilization of thermal energy extracted from photovoltaic module. Simple approach of cooling systems has been designed by means the control of air circulation obtained from the electricity energy output of photovoltaic system [7]. The main challenge to improve the solar thermal cooling technology is the necessary to have the high operating temperature of heat source [8]. In our paper, it is not important to have the high temperature for heating the refrigerant since the type of R22 refrigerant is characterized with low temperature evaporation and the cooler temperature is possibly obtained with increasing the refrigerant pressure. Nevertheless, the solar energy for cooling system applications is still questionable compared to the conventional ones; therefore, the complete life cycle assessment has been conducted for the best topology configuration of grid connected and standalone photovoltaic plants for heating and cooling system application with the case study in Europe [9]. Similar parametric study of heating and cooling systems has been conducted in Algeria under variably climate condition [10]. Based on the wide-ranging review, it may be predicted that with the swelling growth of solar PV electricity worldwide, the compatible cooling system is becoming obligatory in order to ensure better energy harvest and utilization [11].

The important part of our proposed cooling system is actually the heat extraction box which is designed at the backside of PV module. The heat is transferred from the extraction box using water as the medium fluid, while the refrigerant is used as the working fluid in the designed cooling engine. Basically, the main component of our proposed cooling system consists of vacuum motor, windshield pump, refrigerant tank, water tank and solar panels. Because of no electricity energy output of PV module is utilized in our design, the PV module performance in terms of efficiency will be maintained high. The efficiency output is also very dependent on sunlight intensity and the characteristics of medium heat transfer and the type of refrigerant. The cooling system can be developed into a large scale system with updating the type of vacuum motors and upgrading the model construction.

CONFIGURATION OF PROPOSED SYSTEMS

The configuration of cooling system utilizing solar energy is basically similar to the conventional refrigeration systems. The different component is the solar panel for electricity energy output and heat energy collector. The electric current from the terminal output of PV panel is used to power the vacuum motor pump, while the heat energy from the extraction box from the backside of PV module is used to raise the temperature of the liquid refrigerant so that the refrigerant evaporates in the heater tank. The evaporated refrigerant discharges to the cooler tank where the refrigerant temperature reduces by condensation process. The decreased temperature in the cooling tank will be used to cool the water that passes through pipe from the cooling tank to the evaporator by means the room cooling target. The indoors evaporator will continue to process the cold temperatures that are distributed by a fan in the room. The cycle will be repeated as long as the equipment is working. The circulation of hot water, refrigerant and cold water are clearly shown in Figure 1.

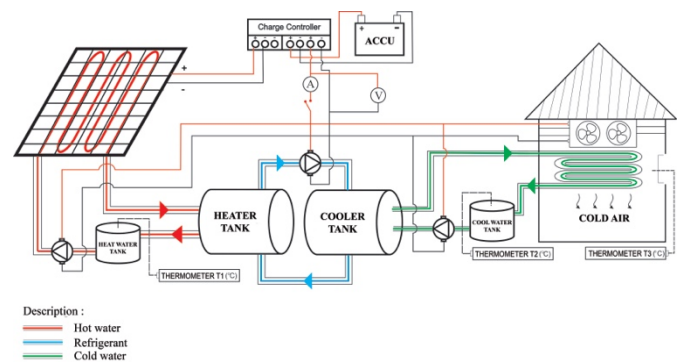

Figure 1. Schematic diagram of cooling system

The details of equipment and component are explained as follows. The photovoltaic panel with 50 W_p of WJ50-M polycrystalline Silicon modules is used as the power supply for the electric component and to capture the heat from the sun designed as the backside of panel. The terminal voltage of PV

panel is 17 Volt connected to the charge controller and battery. The battery model is UXH100-12N of 100Ah, while the charge controller is SCMTTP-10 type with the maximum load current of 10A. The dc vacuum motor of 12V rated voltage for R22/R134a of refrigerant circulation is with 0-6 psi operating pressure, while the water circulation by the windshield pump with the flow rate capability of 2400 ml/min. The room is designed as the cooling room target with dimension of 30x20x40 cm³, complete with the motor fan of DC12025S model for air circulation. The additional components are NYA cable and switches. The operational model of components is shown in Figure 2.

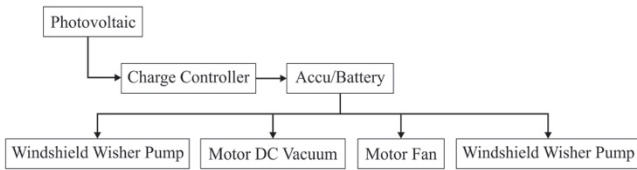

Figure 2. Operational model

The box heat extraction is the most crucial component to be designed in our proposed cooling system. The box is designed with spiral copper pipe of 3/8” inside for the path of water as fluid media to transfer the heat at the backside of PV module. It has been explained that the hot water is used to heat the refrigerant and circulate in one complete process. The dimension of box heat extraction is 85x55x5 cm³ which is depending on the PV module dimension. The cooling performance is indicated by the capability to keep the radiated heat of PV module inside the box extraction.

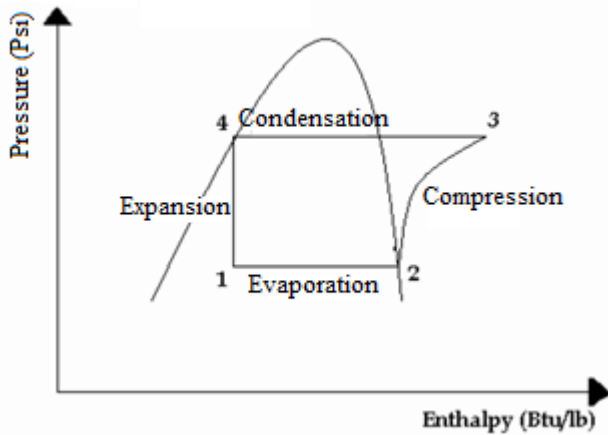

Figure 3. Ideal steam compression in Pressure-vs-enthalpy

In this proposed model, the cooling process is basically following the compression process, caloric discharge flow, refrigeration effect and coefficient of performance as in Figure 3. The compression process in btu/lb is the change of pressure to the enthalpy of the process of expansion, condensation, compression and evaporation. The equation in the steady flow of energy can be expressed as:

$$h_2 + q = h_3 + w; \text{ and } w = h_2 - h_3 \quad (1)$$

where h_2 is the enthalpy from evaporator to compressor in W/m^2oC , h_3 is the enthalpy from compressor to condenser in W/m^2oC , q is the caloric discharge flow in kJ/sec and w is discharge capacity in liter/sec.

Meanwhile, the caloric discharge flow in btu/lb is the calor displacement of refrigerant during the condensation process. In Eq. (1), the steady state energy output could be kinetic, potential energy or just output energy. The caloric discharge flow during the condensation process can be expressed as:

$$q = h_4 - h_3 \quad (2)$$

where h_4 is the enthalpy from condenser to expansion valve in W/m^2oC . In addition, the refrigeration effect (RE) in btu/lb is the caloric transfer during process of h_1-h_2 , where h_1 is the enthalpy between expansion valve and evaporator. The refrigeration effect is the most important part as the main purpose of our designed systems.

$$RE = h_2 - h_1 \quad (3)$$

Finally, the coefficient of performance (COP) becomes the indicator of ideal power, which can be expressed as:

$$COP = \frac{h_2 - h_1}{h_4 - h_3} \quad (4)$$

In this research, the equation in the second cycle is very important where the refrigerant circulates from the heater to cooler tanks.

MEASUREMENT RESULTS AND DISCUSSION

The testing design is to determine the performance of the cooling system. The working mechanism started when the photovoltaic module is constructed on the top of the heat extraction box which is connected to heater tank. The heater tank stores the liquid refrigerant that will be heated by heat energy transfer from solar panel collected in the extraction box. The liquid refrigerant is heated to increase the temperature until the refrigerant evaporates. After that, the vapor of liquid refrigerant is sucked into the tank cooling where the temperature of refrigerant decreases. Finally, the lower temperature of liquid refrigerant flows in the evaporator to make the room temperature goes down.

This research is focused on the cooling systems according to the refrigerant types in different pressure levels. Refrigerant is the cooling agent that may absorb the heat from other materials. In steam compression cycle, the refrigerant is continuously evaporated and condensed. Chemical compounds can be used as the refrigerant if they are safe and economic in terms of chemical physical characteristics as well as the thermodynamic performance. Therefore, the common refrigerant might be from halocarbon, inorganic, hydrocarbon chemical compounds.

There are so many types and codes of refrigerant distinguished from color codes and chemical names. The

research utilizes refrigerant of R22 and R134a according to the cooling purpose and availability type of compressor. The R22 type is a chlorofluorocarbon (CFC) refrigerant of CHClF_2 with pale blue color, while the R134a is a hydrofluorocarbon (HFC) refrigerant of tetrafluoroethane HFC-134a with light blue sky color.

The R22 refrigerant is commonly used in the cooling system with low temperature due to the boiling temperature at atmospheric pressure is very low (-40°C), therefore it is suitable for evaporator temperature of -87°C . However, the output temperature of such refrigerant is high so that the suction of super heat steam must be maintained at the minimum level. If it is necessary, the cooling of head compressor can be recommended, especially for cooling systems with lower temperature. The R22 refrigerant is sometimes mixed with oil; therefore, the oil separator is needed before the refrigerant reaches the evaporator.

Meanwhile, the R134a refrigerant has better characteristics than the R22 refrigerant in terms of non-toxic, fireproof and relatively stable characteristics. Nevertheless, the utilization of R134a is not so simple to replace other types of refrigerant unless the refrigeration system is modified which can be more expensive. In addition, the R134a refrigerant is highly depending on the synthetic lubricants that may cause other problems due to the hygroscopic characteristics.

This research is focused on the cooling systems performance according to the refrigerant types in different pressure levels. The refrigerant of R134a is used for the cooling system design under refrigerant pressure of 1 bar which was tested on Thursday, 25 June 2015 from 1.30 to 2.00 p.m under clear sky condition with the irradiance of $800\text{-}1000 \text{ W/m}^2$. Meanwhile, the test of the same refrigerant and sunlight condition under refrigerant pressure of 2 bars was performed on Sunday, 28 June 2015 from 1.30 to 2.00 p.m. Meanwhile, the measurement under cloudy sky condition with 1 bar air pressure was conducted on Saturday, 27 June 2015 from 1.30 to 2.00 p.m with the irradiance was $400\text{-}600 \text{ W/m}^2$. The 2 bars of refrigerant pressure under cloudy sky condition was performed on Wednesday, 1 July 2015 from 1.30 to 2.00 p.m. The solar light intensity under clear sky condition is higher than the cloudy sky so that the electric and thermal energy yields are consequently high for the maximum performance of overall designed systems. In addition, there is no modified design in our proposed cooling system when implementing the R22 refrigerant for 1 and 2 bars refrigerant pressure, except the day where the measurement was taken.

Figures 4 and 5 show the performance of our cooling system using refrigerant R134a under refrigerant pressure 1 and 2 bars, respectively. Under refrigerant pressure of 1 bar, the cooling system is slowly started where the significant drop temperature after 50 minute for both clear and cloudy sky conditions. The minimum temperature that can be reached is 28.1°C when the measurement is taken under clear sky condition. If the refrigerant

pressure is increased to 2 bars, the drop of temperature is significantly to 23.4°C under clear sky condition. It is due to the increase in water temperature in order to heat the refrigerant following the high level of refrigerant pressure.

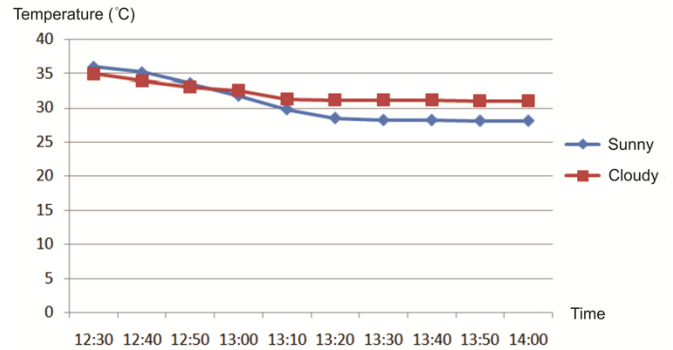

Figure 4. Cooling temperature with R134a type of 1 bar refrigerant pressure

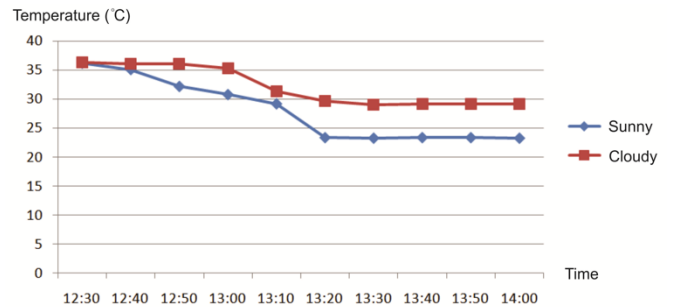

Figure 5. Cooling temperature with R134a type of 2 bars refrigerant pressure

In comparison, the performance of R22 type of refrigerant under 1 bar of refrigerant pressure with R134a is basically similar under cloudy condition. However, the lower temperature of 27°C can be reached under clear sky condition when using R22 type of refrigerant (Figure 6). When the refrigerant pressure increases, the minimum temperature that can be reached is 20.8°C under clear sky condition (Figure 7). Therefore, it is important to notice that the performance of R22 type of refrigerant is better than R134a regarding to room temperature results obtained in this measurement. However, the power consumption is gradually increased when the room temperature decreases as results of powering all the electrical components of system. Nevertheless, the change in power usage is stable for both clear sky and cloudy sky conditions under the same refrigerant pressure (Table 1).

The room temperature obtained in this research is not drastically reached very low but it is good enough to fulfill the standard cooling room temperature with low power consumption. The results are highly depending on the weather condition where the proposed system is based on the thermal heat from the Sun. That is why the lower temperature cannot be reached under cloudy or rainy condition. Also, the system

component affecting the overall system performance, such as the vacuum motor and refrigerant tank are maximally designed for the refrigerant pressure under 3 bars. In this case, the lower temperature of cooling system might be reached if the refrigerant pressure increases. It means that some modification of component is necessary to make total improvement in terms of cooling temperature of proposed system.

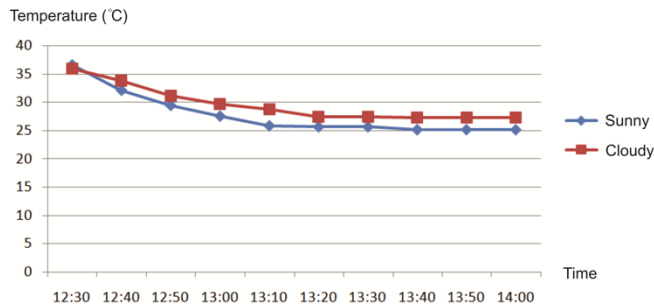

Figure 6. Cooling temperature with R22 type of 1 bar refrigerant pressure

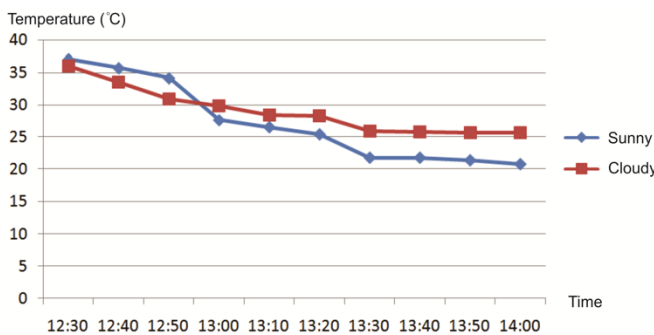

Figure 7. Cooling temperature with R22 type of 2 bars refrigerant pressure

Table 1. Power consumption utilized from solar panel output

NO.	TIME	POWER(WATT)							
		REFRIGERANT R134a				REFRIGERANT R22			
		SUNNY		CLOUDY		SUNNY		CLOUDY	
1 BAR	2 BAR	1 BAR	2 BAR	1 BAR	2 BAR	1 BAR	2 BAR		
1	12:30	42.504	42.035	40.29	40.5	42.47	42.273	40.854	41.847
2	12:40	43.82	42.91	42.77	43.056	43.09	42.568	43.214	41.218
3	12:50	43.785	44.208	43.33	43.142	42.07	43.23	44.104	41.838
4	13:00	42.912	44.532	42.42	43.216	43.4	43.622	43.358	42.568
5	13:10	43.128	44.532	43.295	43.364	44.8	42.84	42.636	42.948
6	13:20	43.435	44.568	43.26	44.194	44.8	45.658	43.966	45.708
7	13:30	44.03	44.64	43.26	44.65	43.92	44.659	44.384	47.97
8	13:40	43.085	45.362	44.532	44.889	44.352	47.36	44.07	48.708
9	13:50	44.784	46.55	44.568	47.068	44.64	47.892	44.265	47.15
10	14:00	44.928	46.664	44.568	46.04	45.72	47.619	44.889	47.232
AVERAGE		43.6411	44.6001	43.2293	44.0119	43.9262	44.7721	43.574	44.7187

Nevertheless, the proposed design of cooling system has several advantageous compared to other conventional cooling systems. It is as simple design where the components are easily found in the nearby market. Also, the saving electricity energy consumption in domestic application might be reduced due to the increasing temperature of refrigerant is from the solar thermal

energy, not from grid electricity. The overall result is the efficiency of photovoltaic systems is indirectly improved as the electricity and thermal energy can be simultaneously utilized in the load side.

CONCLUSION

The cooling system design has been presented utilizing the thermal energy output of photovoltaic system for heating the refrigerant. This is another approach for cooling system since the heating refrigerant is not from electricity energy as commonly used in conventional cooling system. The results indicate that the performance of cooling system with type of R22 refrigerant is better than the R134a refrigerant in overall condition and different refrigerant pressure. The lowest cooling temperature is 20.8°C using R22 refrigerant under clear sky condition and refrigerant pressure of 2 bars. It is due to the R22 refrigerant is characterized as low temperature refrigerant. Therefore, it is not necessary to have high thermal energy to heat the R22 refrigerant in order to reach the low temperature of cooling systems. The results might be improved by the designing the vacuum motor and refrigerant tank for refrigerant pressure over 2 bars.

ACKNOWLEDGMENTS

The research grant support is from Ministry of Research, Technology and Higher Education of Indonesia under research scheme of PUPT 2016.

NOMENCLATURE

h_1	enthalpy between expansion valve and evaporator
h_2	enthalpy from evaporator to compressor
h_3	enthalpy from compressor to condenser
h_4	enthalpy from condenser to expansion valve
q	caloric discharge flow
w	discharge capacity
RE	refrigeration effect
COP	coefficient of performance

REFERENCES

- [1] Syafaruddin, Andani Achmad, Tajuddin Waris, Zulkifli Tahir, Yulianto Dwi Putra: 'Application of Microcontroller ATmega8535 for Hybrid Photovoltaic –Thermal (PV/T)', International Journal of Engineering and Technology (IJET), Vol.5, No.5, pp. 4388-4399, October-November 2013
- [2] S. Sargunanathan, A. Elango, S. Tharves Mohideen, 'Performance enhancement of solar photovoltaic cells using effective cooling methods: A review', Renewable and Sustainable Energy Reviews, Vol. 64, pp. 382-393, October 2016
- [3] Juwel Chandra Mojumder, Wen Tong Chong, Hwai Chyuan Ong, K.Y. Leong, Abdullah-Al-Mamoon, 'An experimental investigation on performance analysis of air type photovoltaic thermal collector system integrated with cooling fins design', Energy and Buildings, Vol. 130, pp. 272-28, 15 October 2016

- [4] S.S.S. Baljit, Hoy-Yen Chan, Kamaruzzaman Sopian, 'Review of building integrated applications of photovoltaic and solar thermal systems', *Journal of Cleaner Production*, Vol. 137, pp. 677-689, 20 November 2016
- [5] Farideh Yazdanifard, Ehsan Ebrahimnia-Bajestan, Mehran Ameri, 'Investigating the performance of a water-based photovoltaic/thermal (PV/T) collector in laminar and turbulent flow regime', *Renewable Energy*, Vol. 99, pp. 295-306, December 2016
- [6] Tingting Yang, Andreas K. Athienitis, 'A review of research and developments of building-integrated photovoltaic/thermal (BIPV/T) systems', *Renewable and Sustainable Energy Reviews*, Vol. 66, pp. 886-912, December 2016
- [7] Syafaruddin, Salama Manjang, Wahyu H. Piarah, 'Photovoltaic System Powering Automatic Control of Air Circulation', *Proc. of The 2nd IEEE Conference on Power Engineering and Renewable Energy (ICPERE) 2014*, 9-11 December 2014, pp.296-301, Kuta-Bali, Indonesia.
- [8] Jinyi Guo, Simao Lin, Jose I. Bilbao, Stephen D. White, Alistair B. Sproul, 'A review of photovoltaic thermal (PV/T) heat utilisation with low temperature desiccant cooling and dehumidification', *Renewable and Sustainable Energy Reviews*, Vol. 67, pp. 1-14, January 2017
- [9] Marco Beccali, Maurizio Cellura, Sonia Longo, Francesco Guarino, 'Solar heating and cooling systems versus conventional systems assisted by photovoltaic: Application of a simplified LCA tool', *Solar Energy Materials and Solar Cells*, Vol. 156, pp. 92-100, November 2016
- [10] S. Bahria, M. Amirat, A. Hamidat, M. El Ganaoui, M. Slimani, 'Parametric study of solar heating and cooling systems in different climates of Algeria – A comparison between conventional and high-energy-performance buildings', *Energy*, Vol. 113, pp. 521-535, 15 October 2016
- [11] M. Hasanuzzaman, A.B.M.A. Malek, M.M. Islam, A.K. Pandey, N.A. Rahim, 'Global advancement of cooling technologies for PV systems: A review', *Solar Energy*, Vol. 137, pp. 25-45, 1 November 2016